

CONSTRUCTION and LOCI

Page	Description
1	Constructing a triangle. Angle, Side, Angle
2	Constructing a triangle. Side, Angle, Side
3	Constructing a triangle. Side, Side, Side
4	Constructing a triangle. Mixed questions
5	Perpendicular Bisector of a line. LOCI - equidistance from two points
6	Bisecting an angle. LOCI - equidistance from two lines
7	Perpendicular from a point to a line
8	Perpendicular at a point on a line
9	Constructing a 60° angle
10	Recap on main Loci ideas
11	Loci examples
12	More Loci examples

Angle, Side, Angle

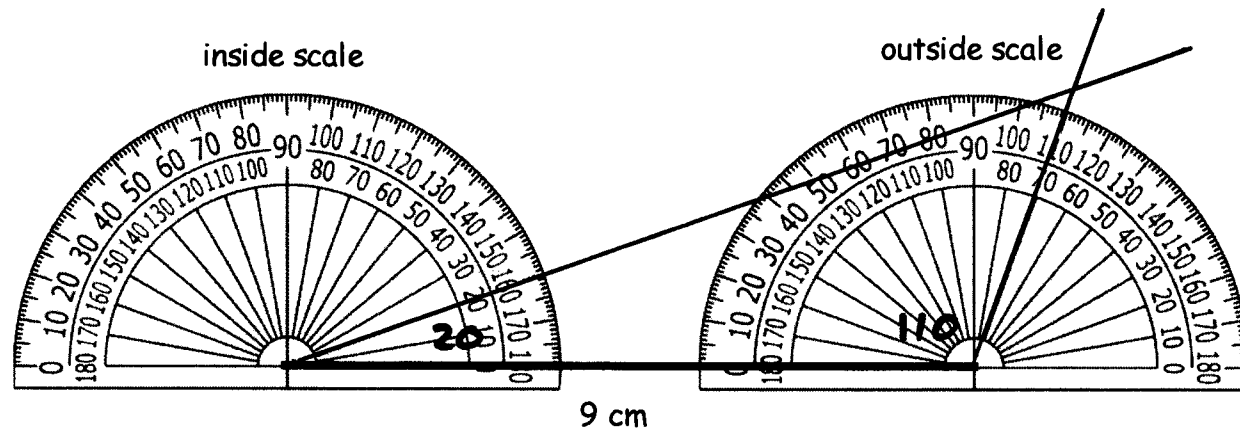
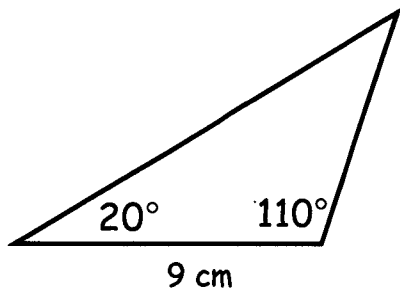
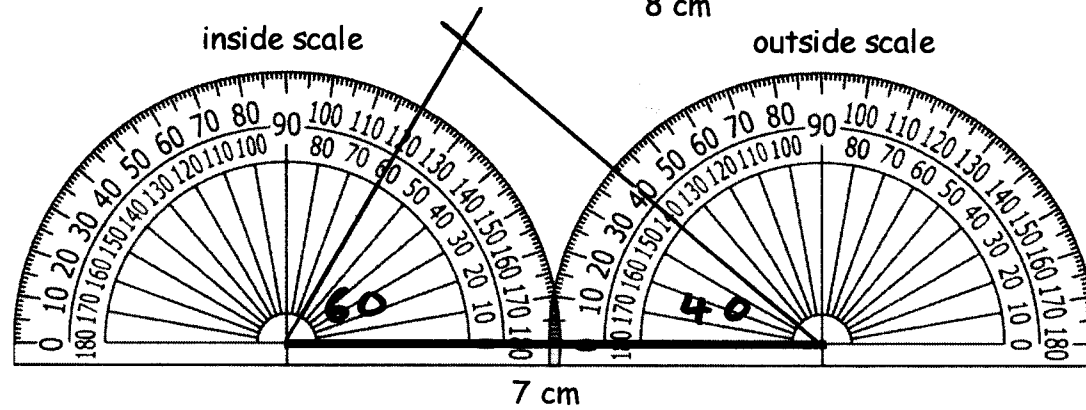
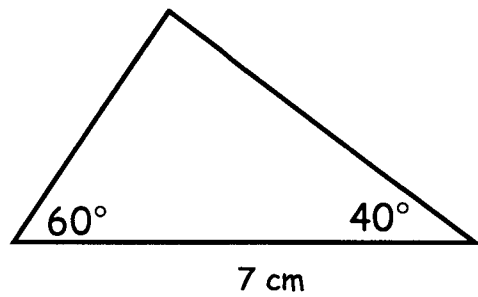
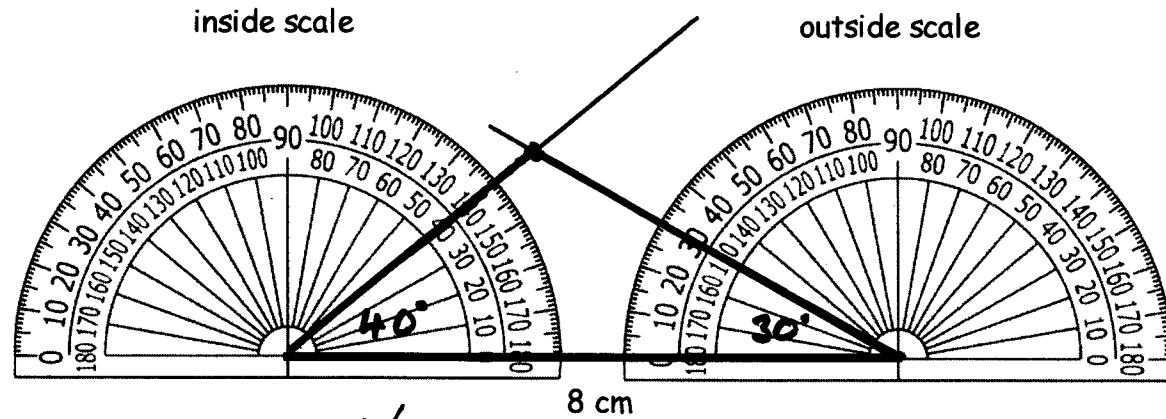
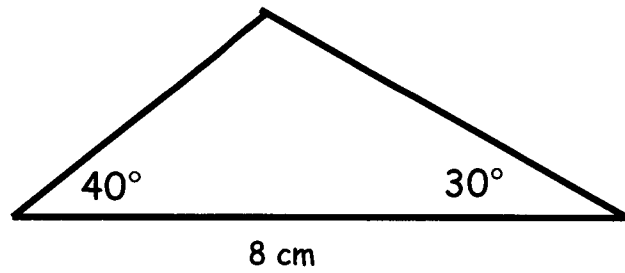

Side, Angle, Side

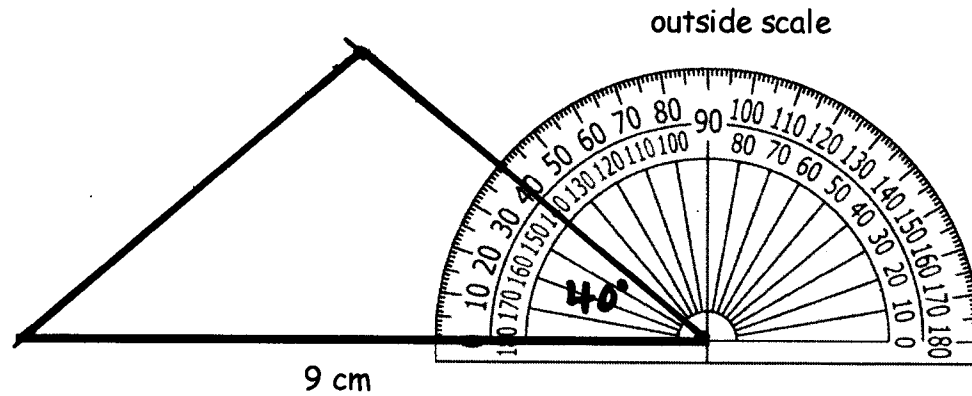
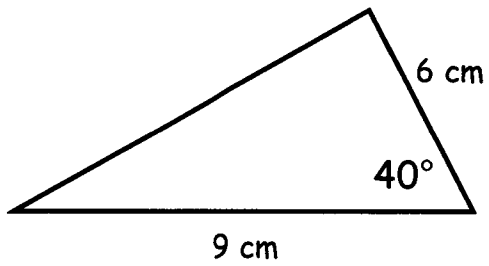
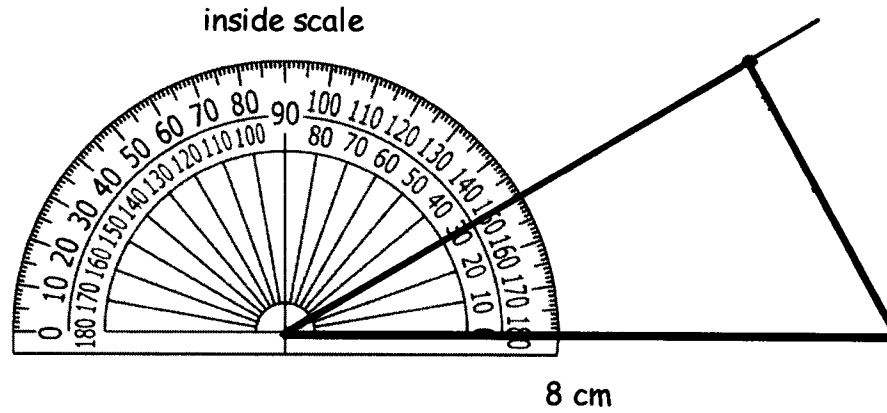
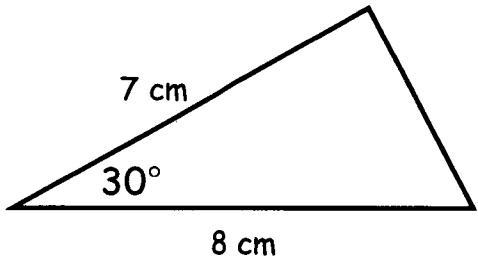
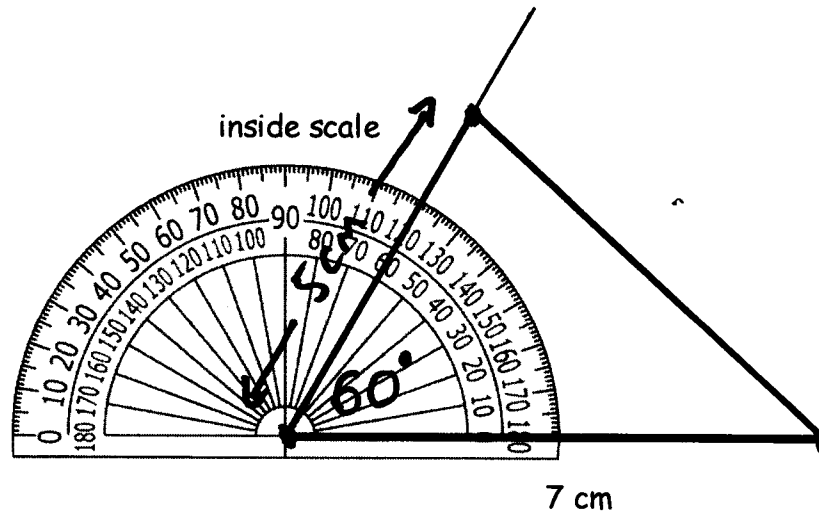
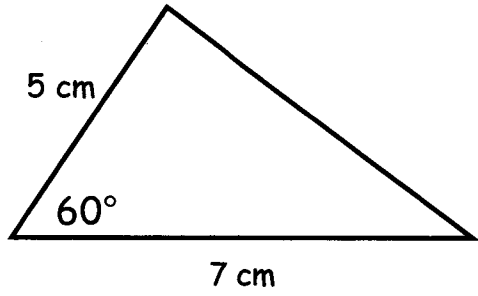

Side, Side, Side

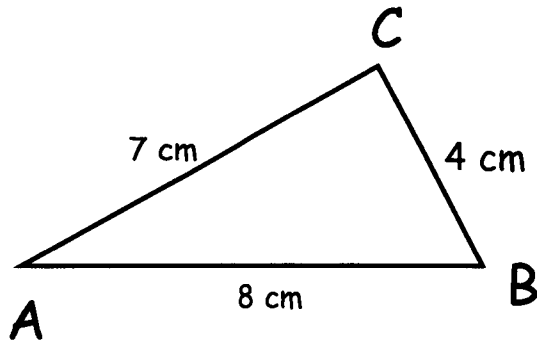

Draw line AB, exactly 8 cm

Where the two arcs cross is point C.
Draw in the lines AC and BC to make
the triangle

Don't rub out the construction lines

compass
set to 7 cm
Draw an arc
centre A

compass
set to 4 cm
Draw an arc
centre B

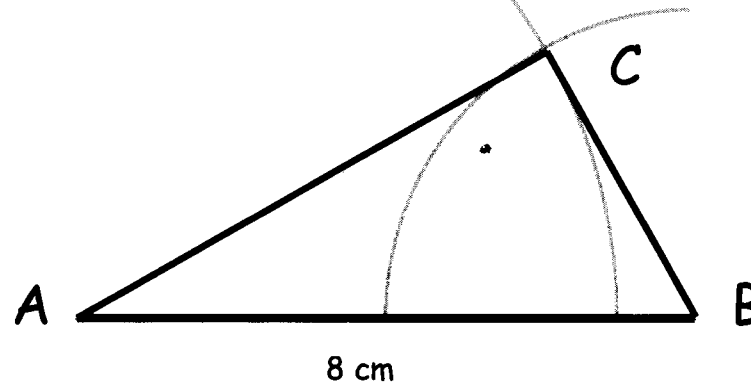

Construct accurately the following triangles. Label each triangle.

Measure missing lengths and angles

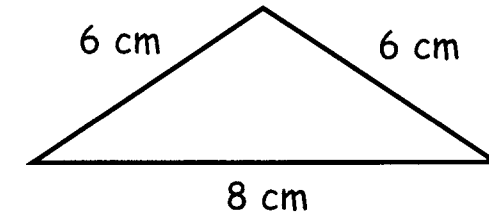
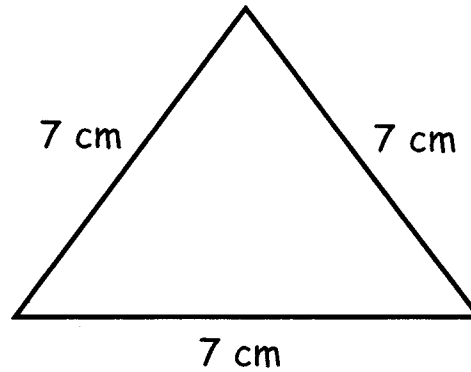
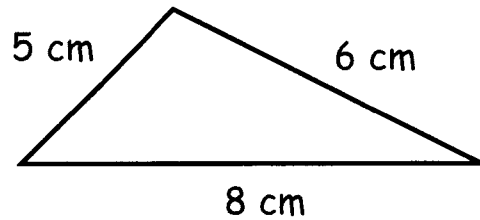
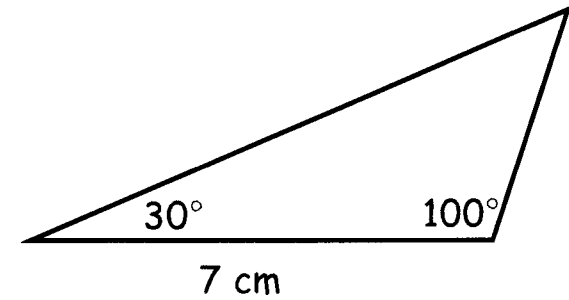
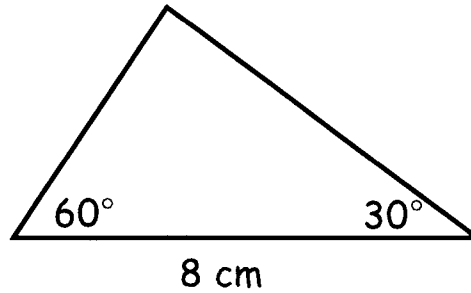
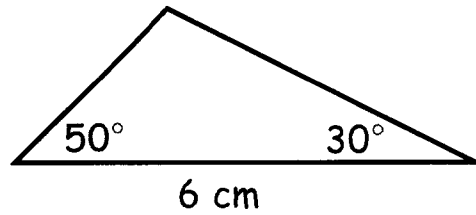
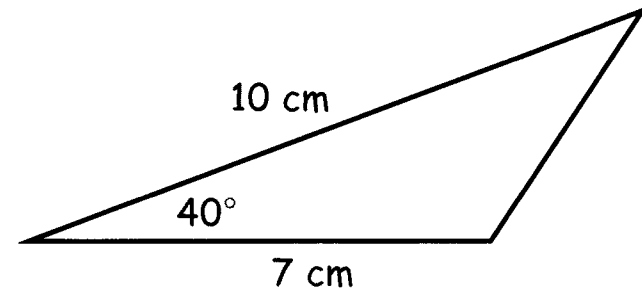
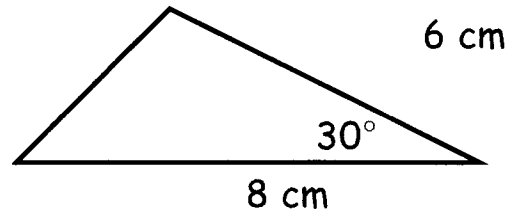
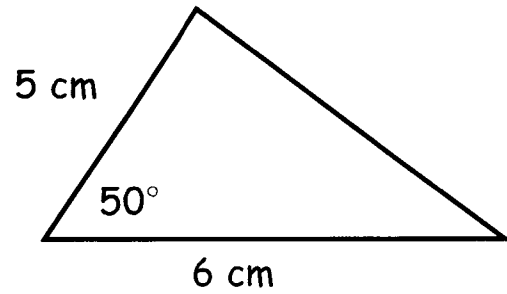

Perpendicular Bisector of a line (LOCI equidistance from two points)

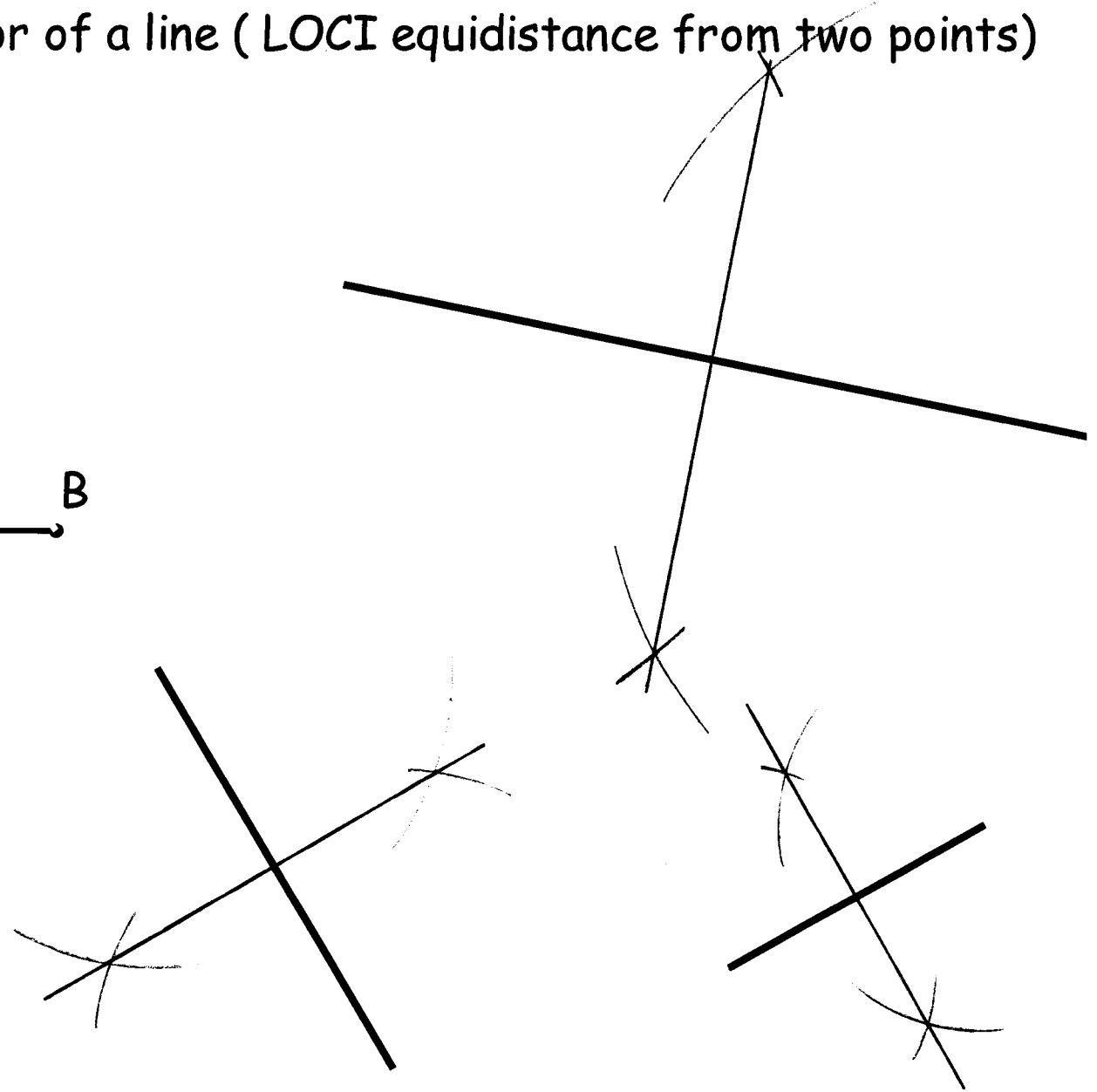
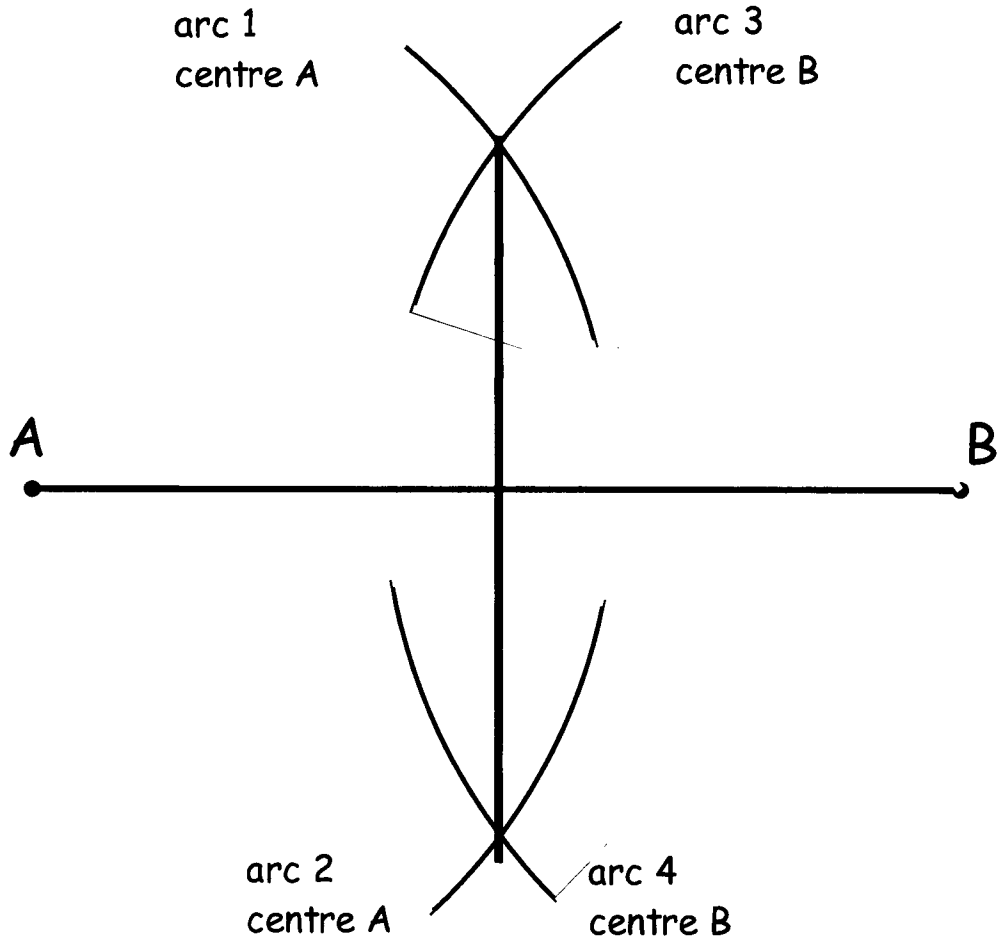

All arcs are the same length. This length must be more than half the length of the line.

Bisecting an angle (LOCI equidistance from two lines)

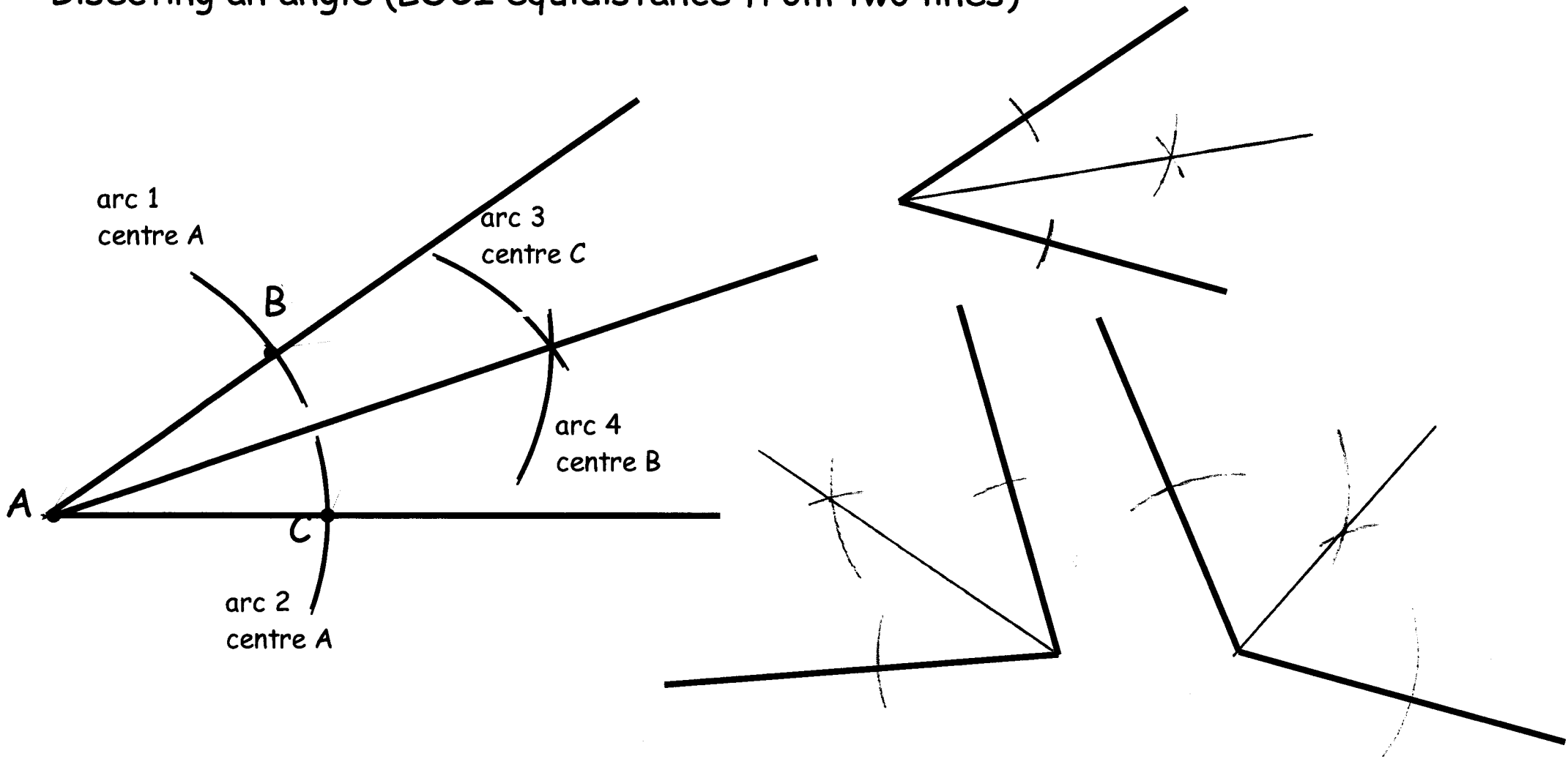

All arcs are the same length.

Perpendicular from a point P to a line

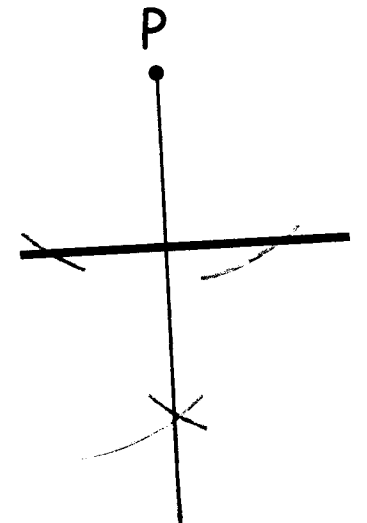
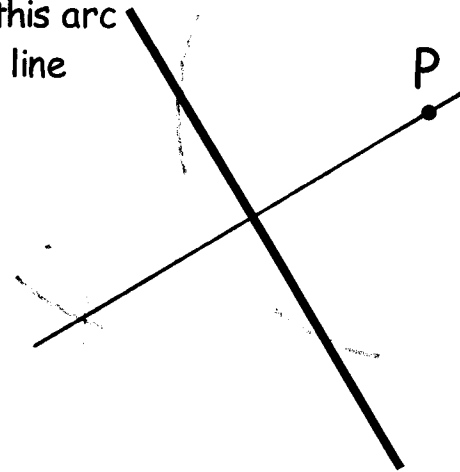
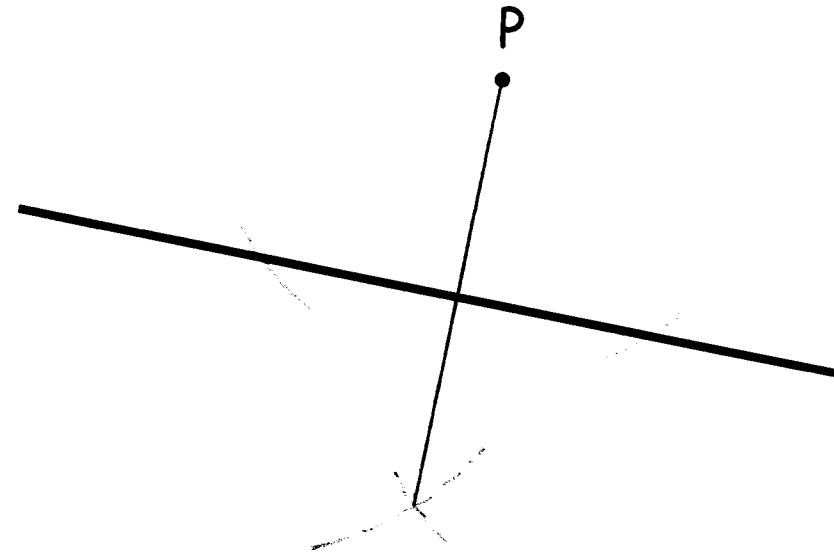
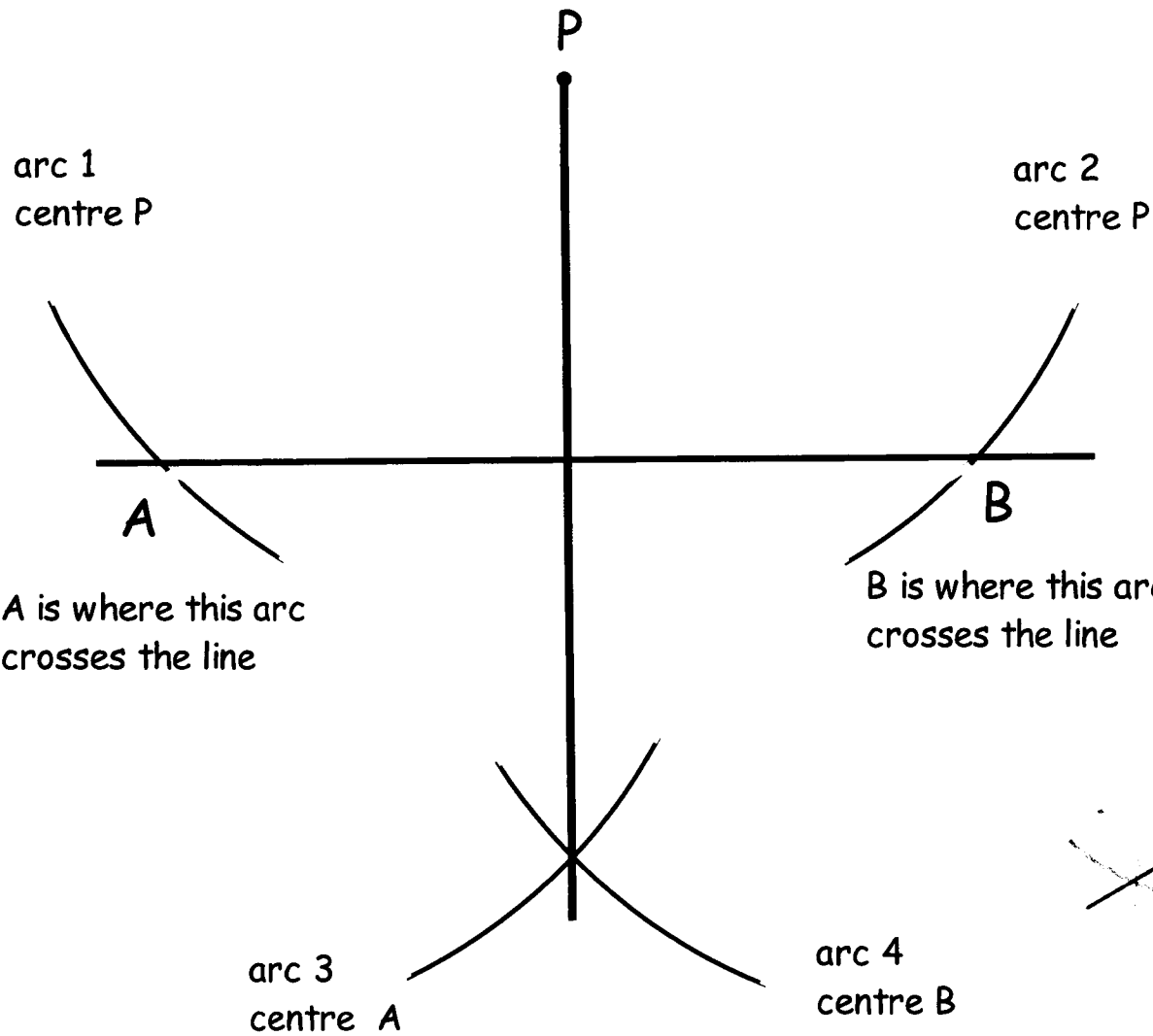

All arcs are the same length. This length must be more than the perpendicular distance from the point P to the line.

Perpendicular at a point P on a line

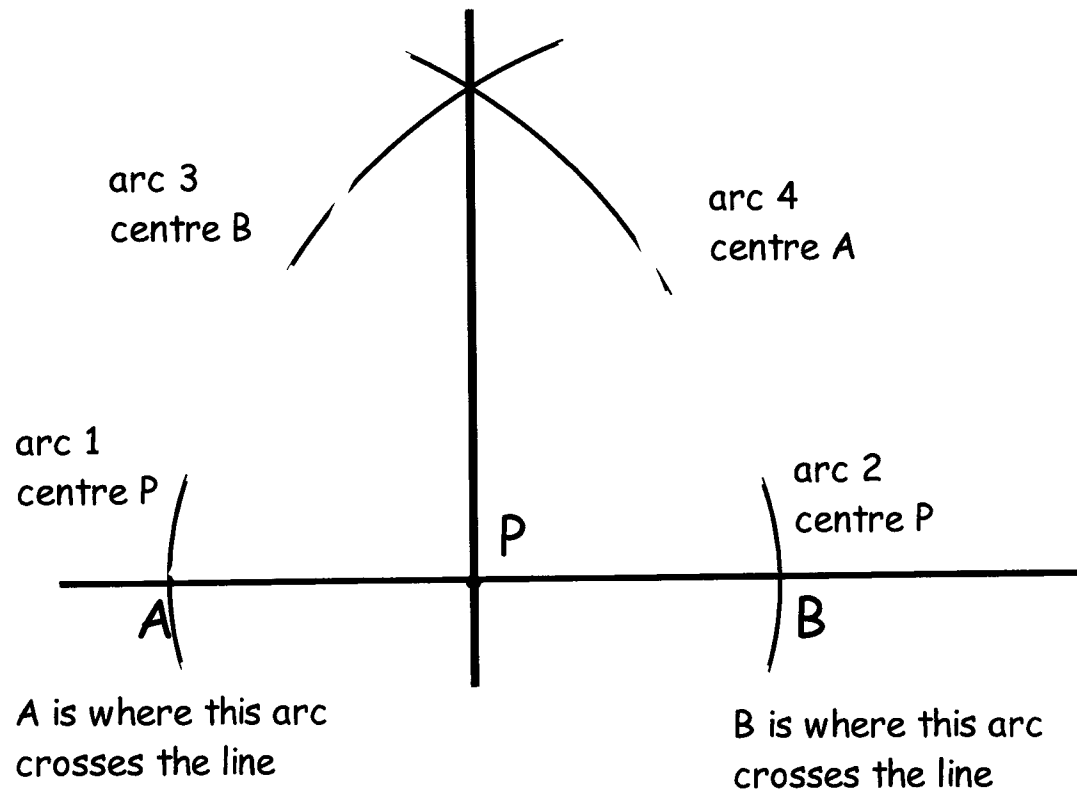

Arcs 1 and 2 are the same length.

Arcs 3 and 4 are the same length.

Arcs 3 and 4 must be longer than arcs 1 and 2.

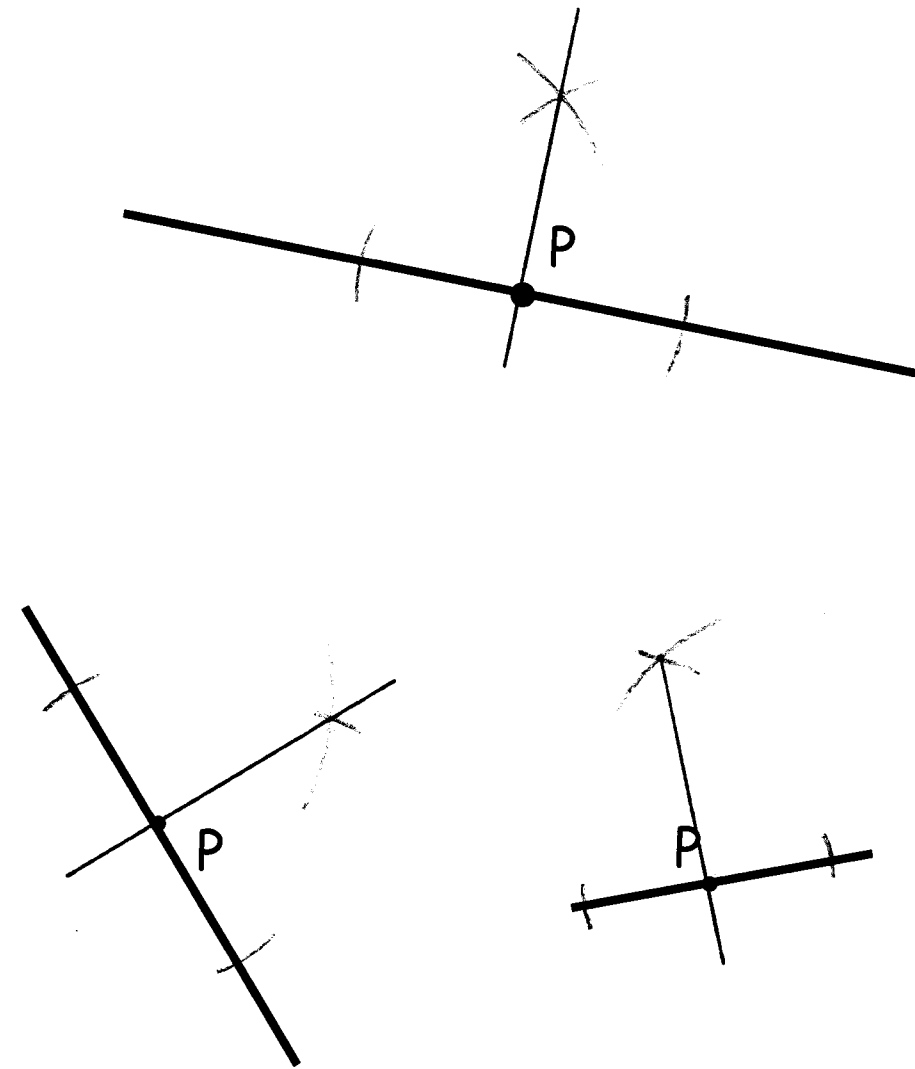

Constructing a 60° angle (Drawing an Equilateral Triangle)

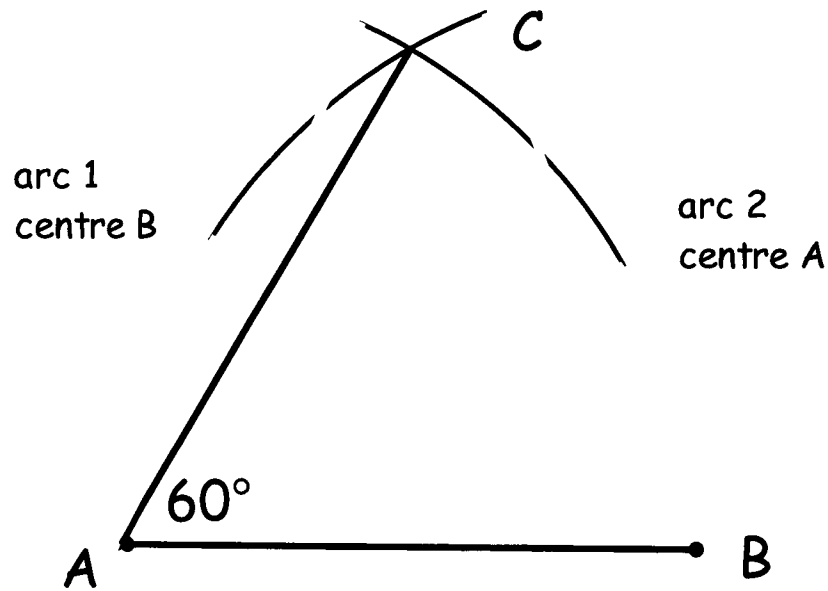

Construct 60° angles on these lines

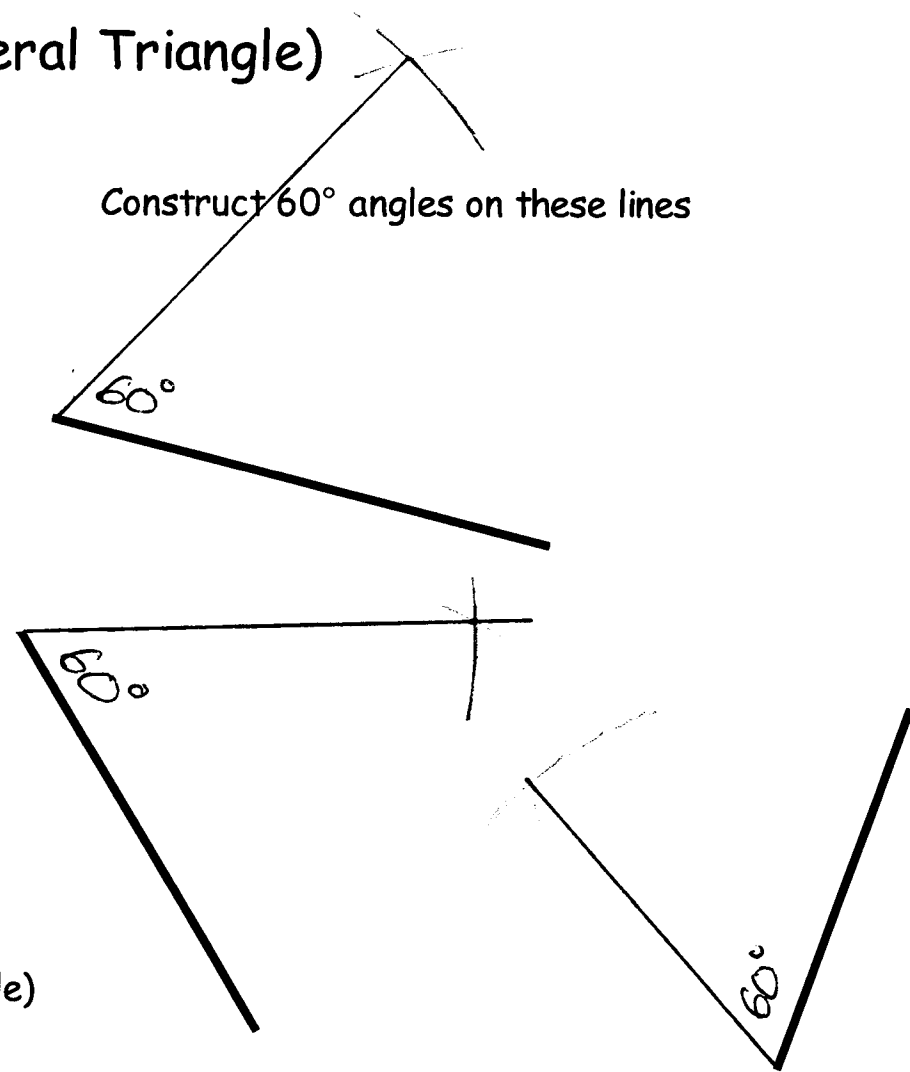

Draw a line 7.5 cm long. (doesn't matter how long)

Arcs 1 and 2 must be the same length as your line (7.5 cm in this example)

Where the two arcs cross is point C

Draw the line AC. Angle CAB is 60°

LOCI

Loci refers to a point or set of points that meet certain geometrical conditions

The loci of points less than 2 cm from A and less than 3 cm from B

The loci of points inside the rectangle that are less than 1 cm from the line AB

The loci of points 2 cm from A

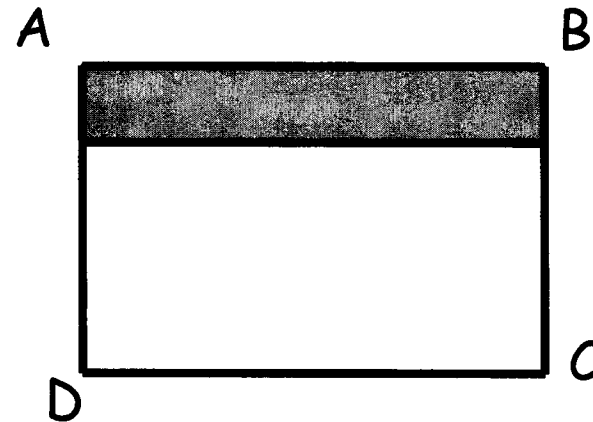
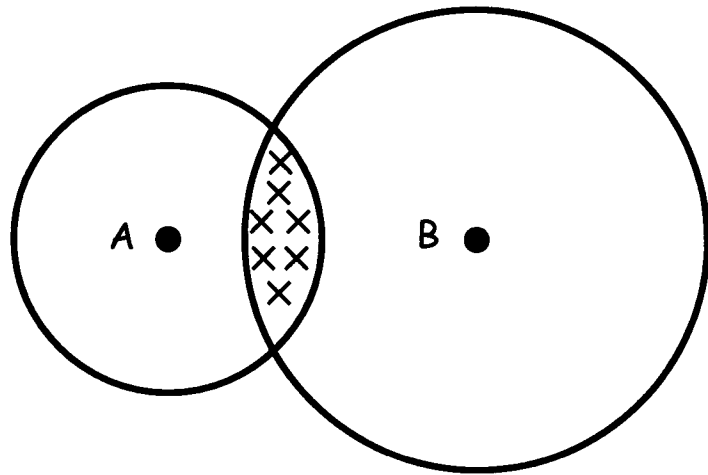
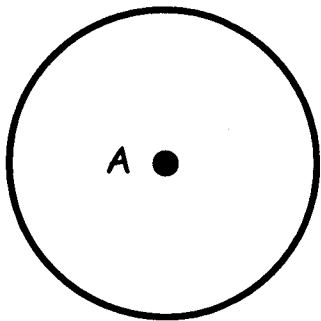

The loci of points that are equal distance from points A and B. This is the Perpendicular Bisector of a straight line construction

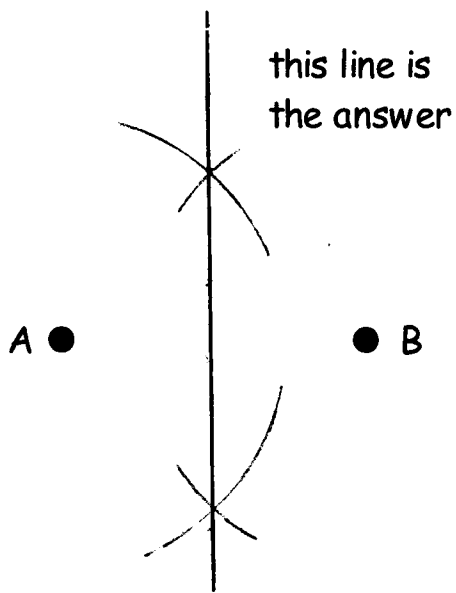

The loci of points that are equal distance from the two lines AB and AC. This is the Bisector of an angle construction

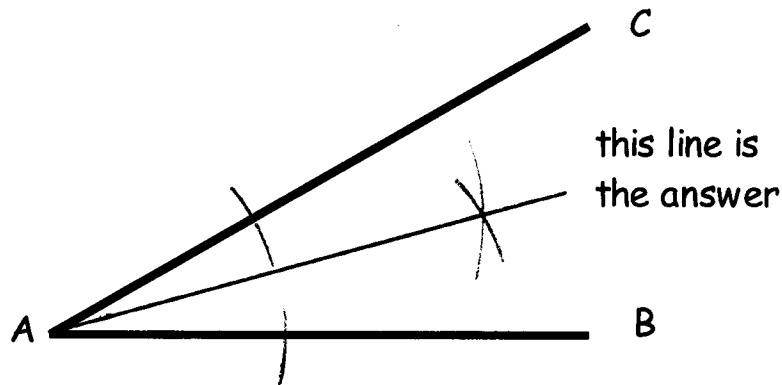

The loci of points that are 1 cm from the line AB



Locus of points 3m or less from A

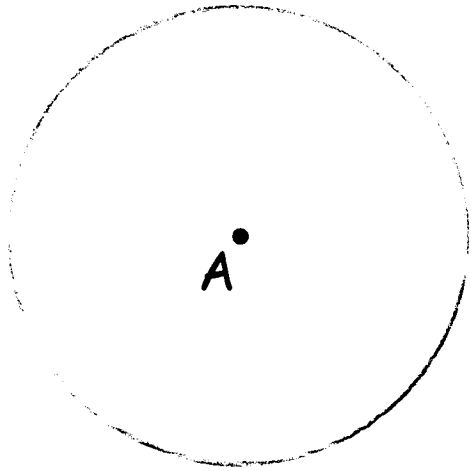

Locus of points 3m or less from A and 2m or less from B

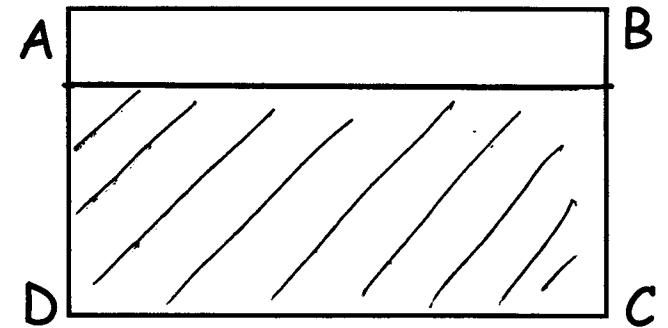
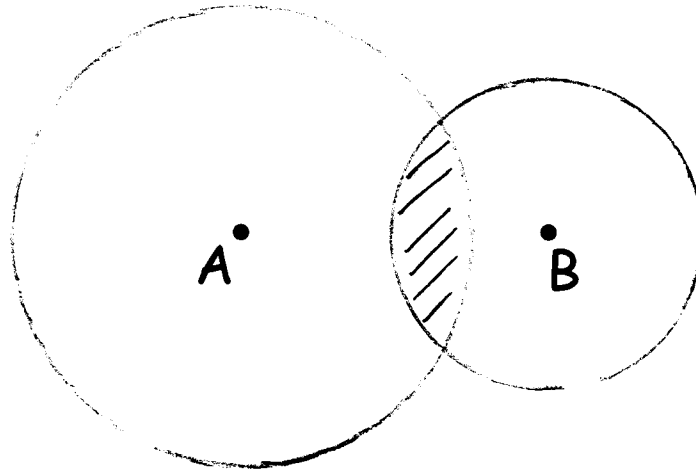

Locus of points more than 1m from line AB.

Locus of points equidistant from A and B:
perpendicular bisector

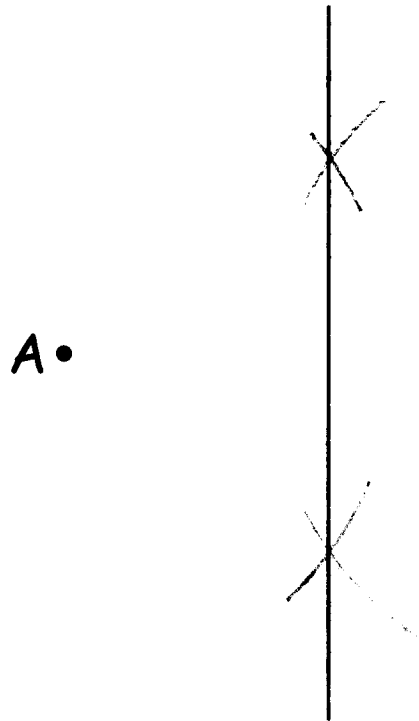

Locus of points equidistant from
lines AB and AC: angle bisector

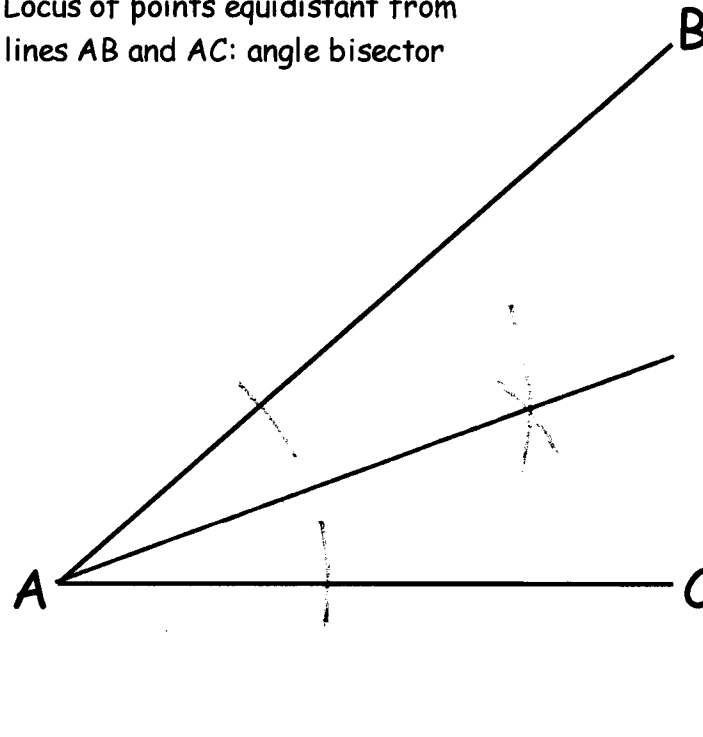

(11)

This is a plan view of a room. Shade where A cannot see in the room?

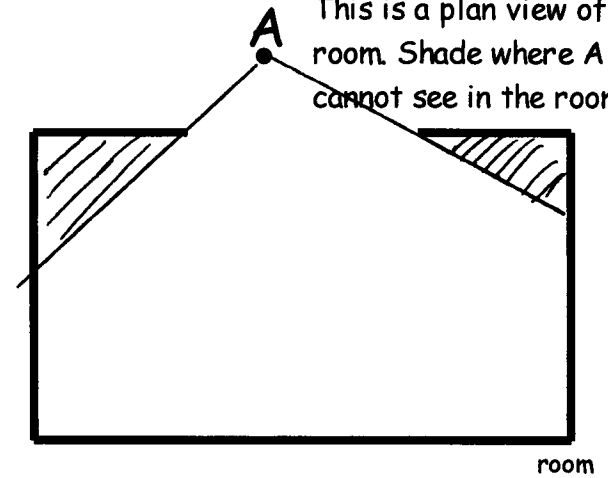

This is a plan view of two people and a high wall. Shade where neither A nor B can be seen due to the wall.

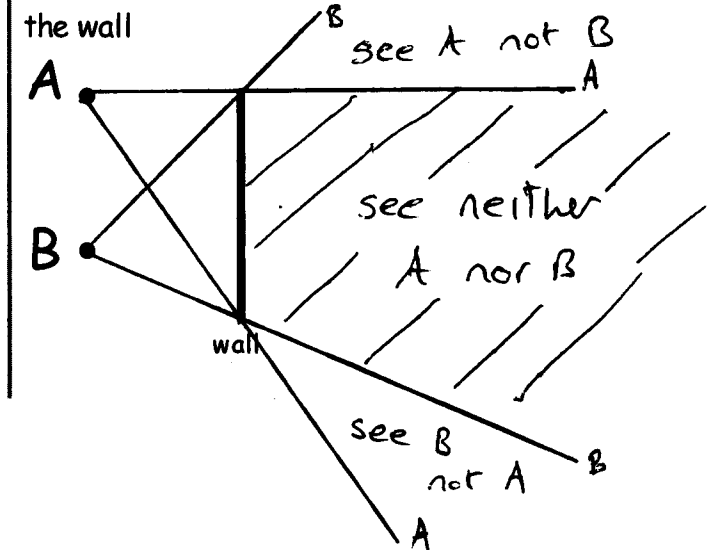

Locate the point X.

It is equidistant from lines AB and AC.

It is equidistant from the points D and E.

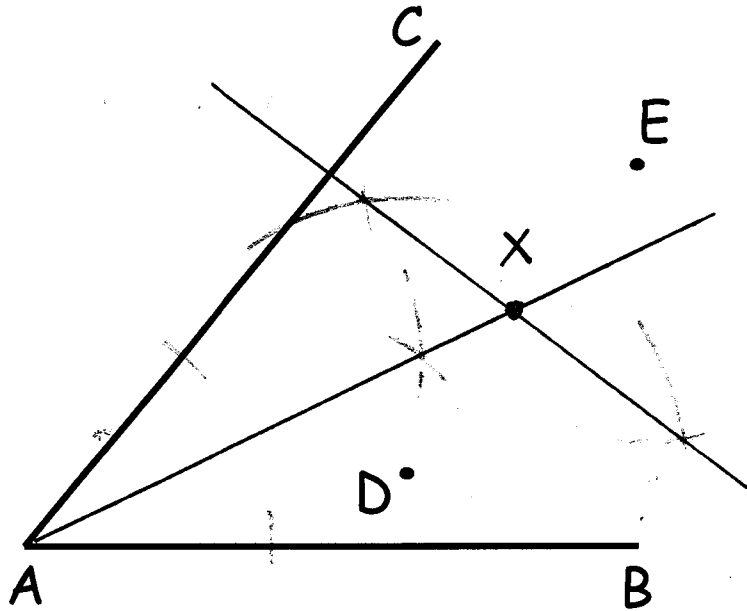

Draw loci of points less than 2m from this L shaped wall.

Scale 1cm = 1m

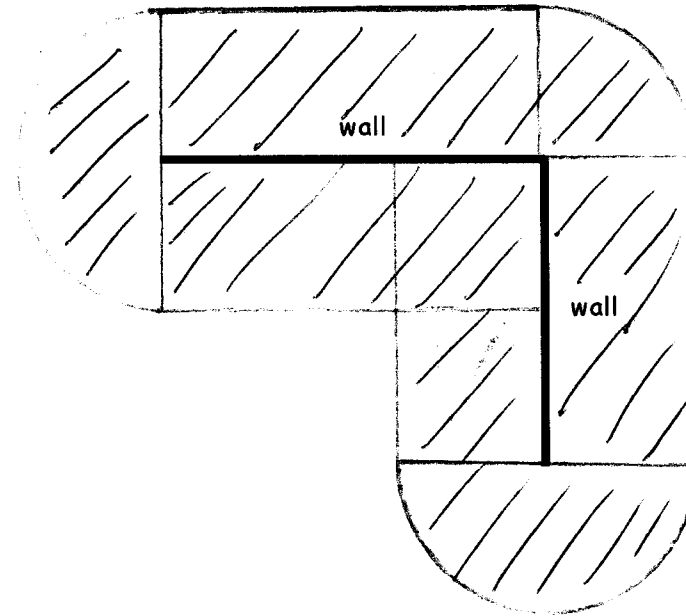

The picture shows a rectangular pond. Geoff wants to put a fence round the pond so that each point on the perimeter of the pond the fence is 1 m away. Scale 1 m = 2cm. Draw the fence.

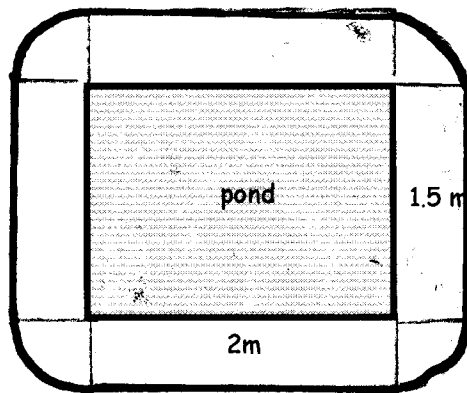

Greg walks from point D towards the towers. Mark where he can see -

1) A, B and C, 2) A and B, 3) only A.

