

ANGLE PROPERTIES of CIRCLES

Page	Description
1	Notes on the main ideas and theories
2	Examples of angle theories inside a circle
3	Further practise of angle theories inside a circle
4	ngle theories using a tangent to a circle
5	Mixed examples, questions 1 to 5
6	Mixed examples, questions 5 to 10

Angle at the centre is twice the angle at the circumference

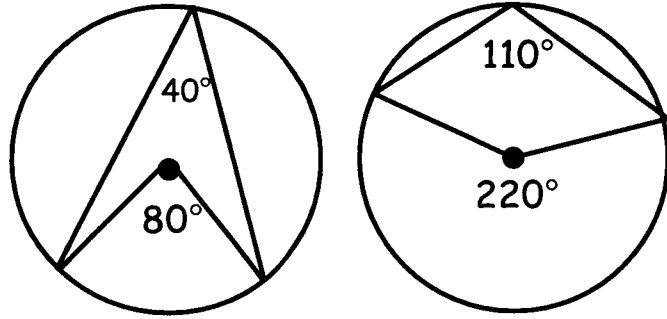

Opposite angles of a cyclic quadrilateral add to 180

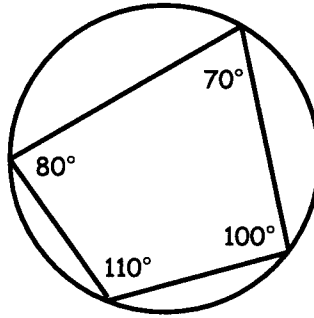

The angle in a semicircle is a right angle

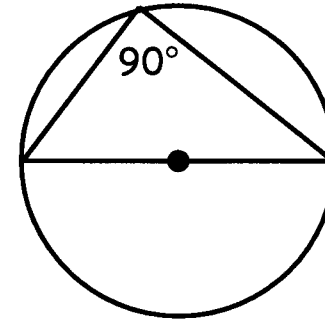

Angles drawn in the same segment are equal

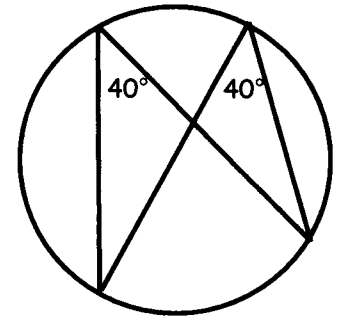

The tangent at any point on a circle is perpendicular to the radius at that point

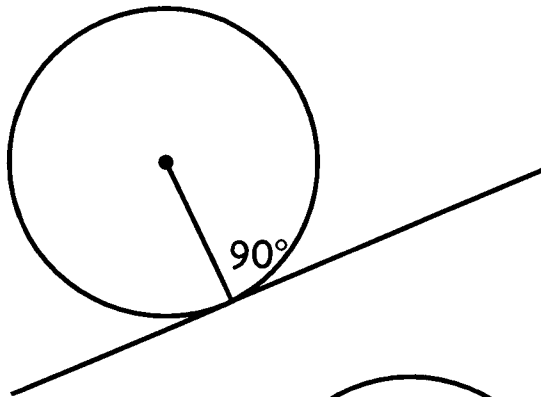

Tangents from an external point are equal in length

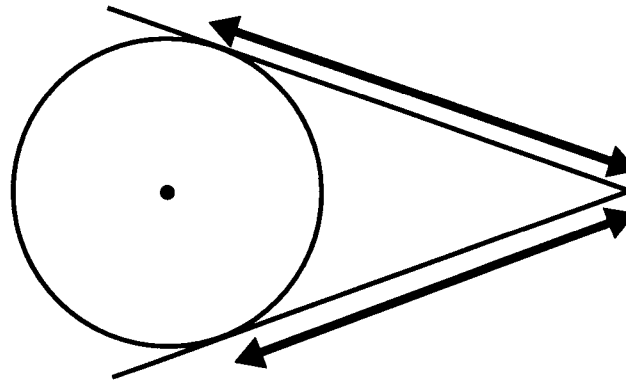

The alternate segment theorem. The angle between tangent and chord is equal to the angle in the alternate (other) segment

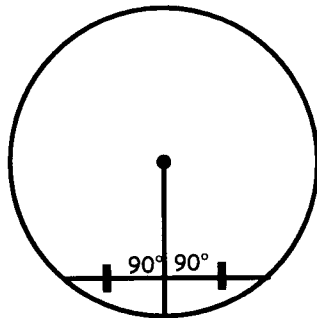
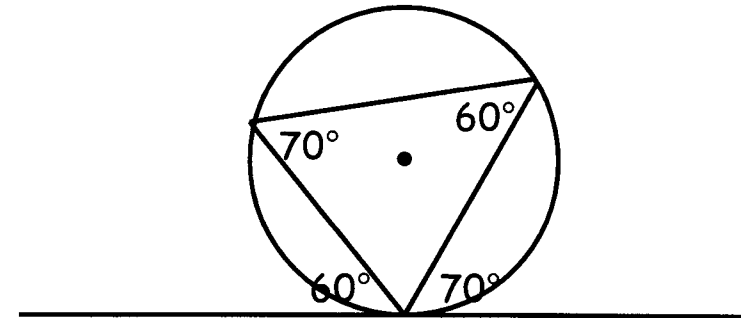

The perpendicular from the centre of a circle to a chord bisects the chord

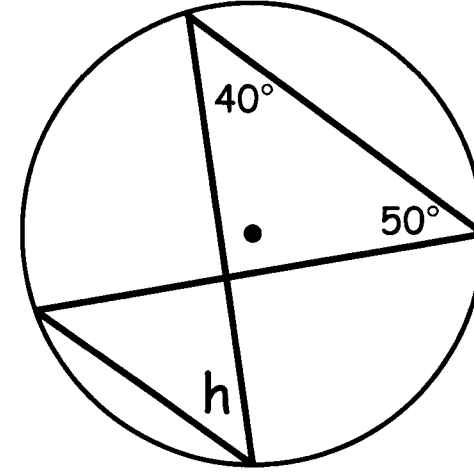
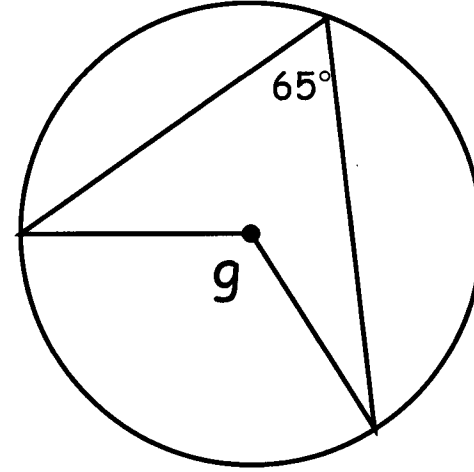
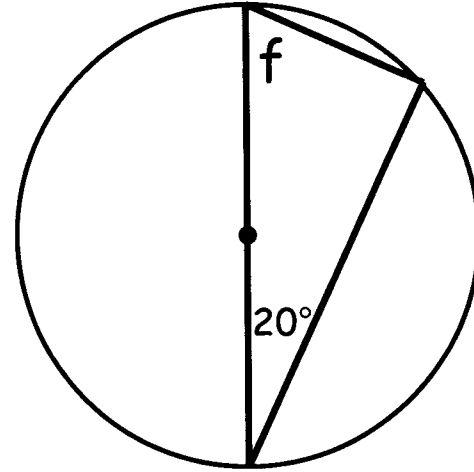
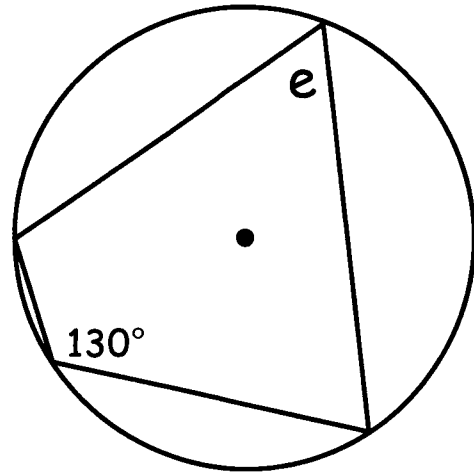
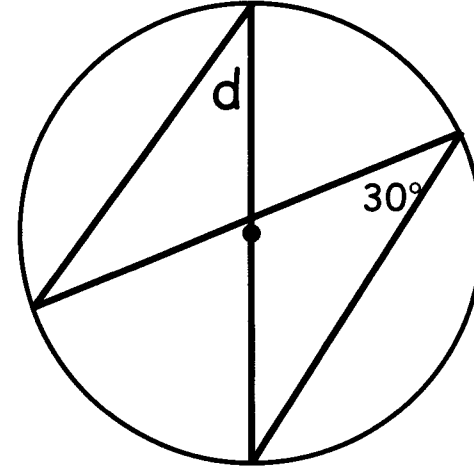
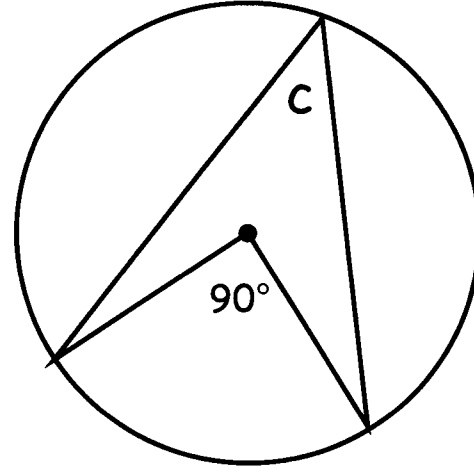
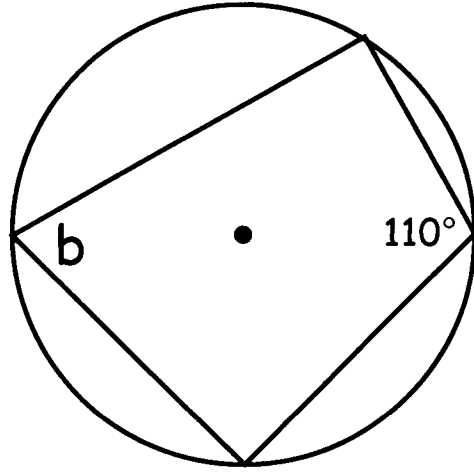
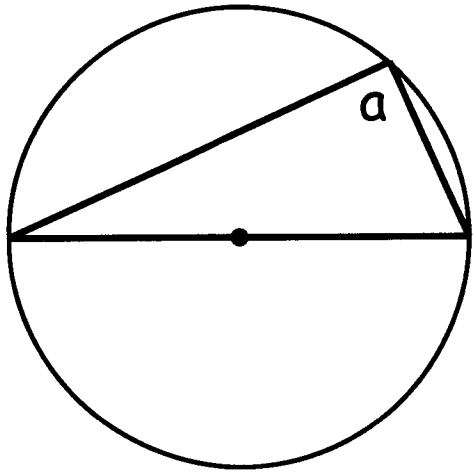

③

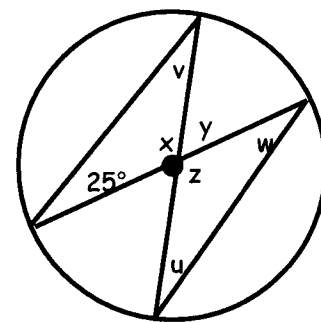
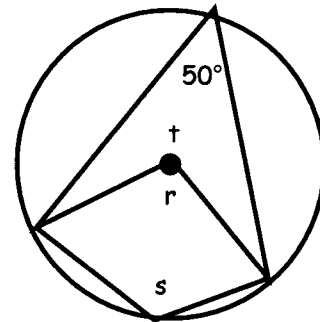
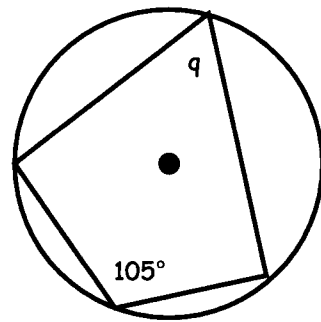
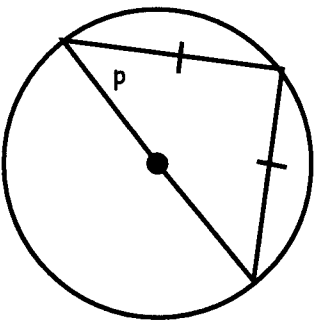
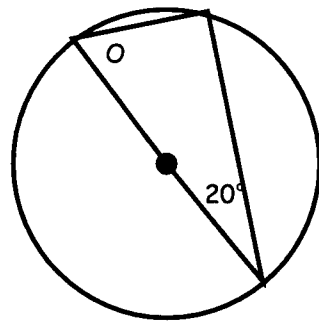
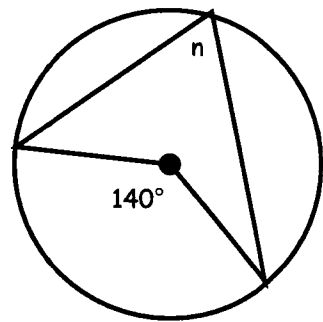
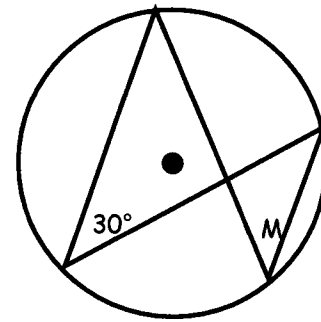
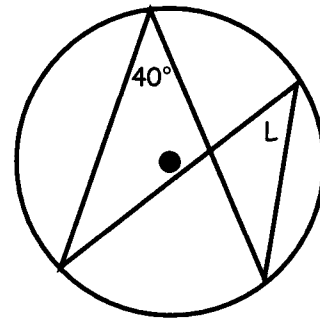
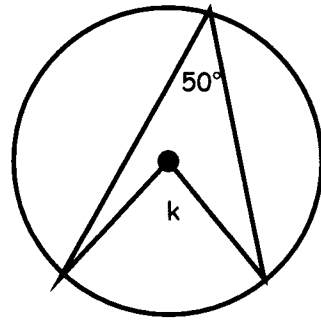
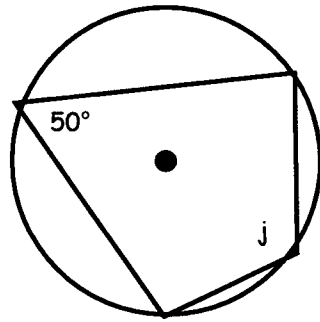
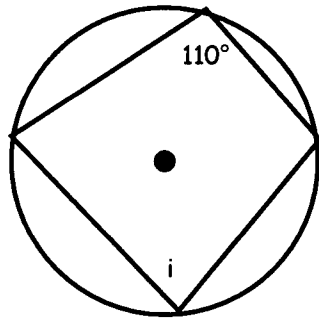
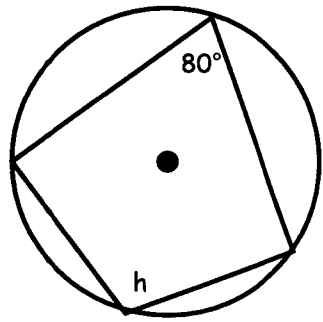
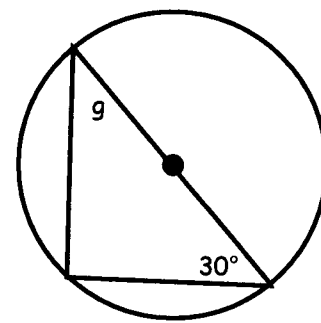
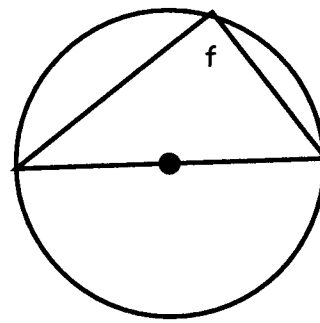
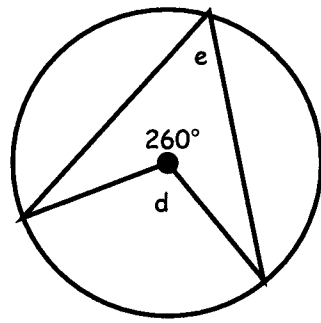
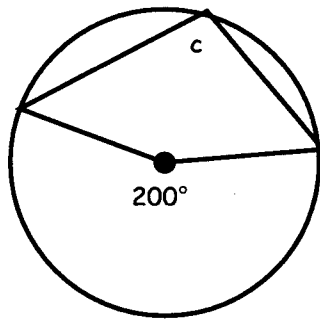
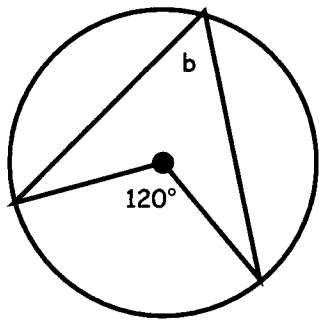
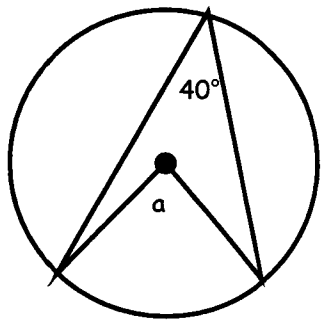

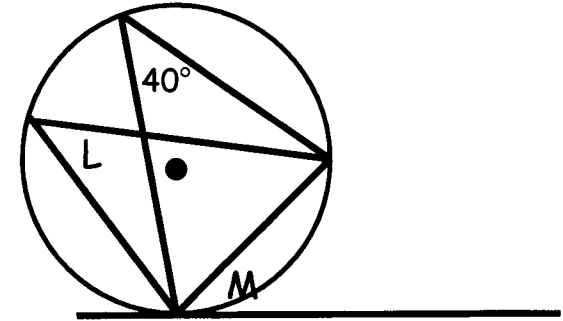
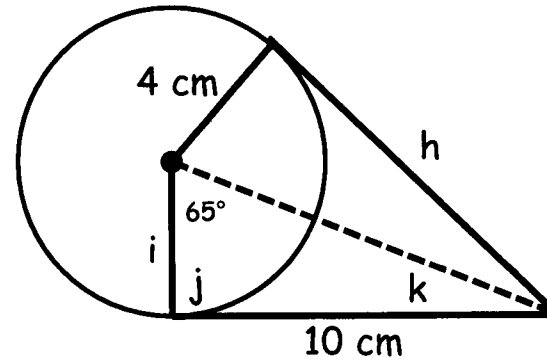
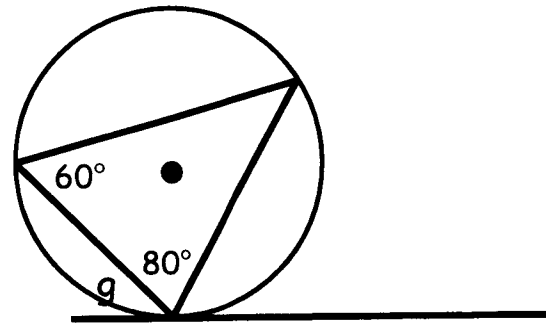
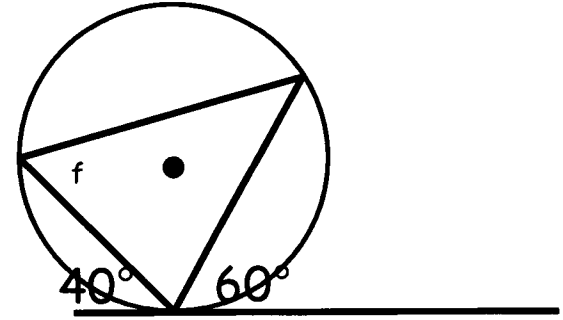
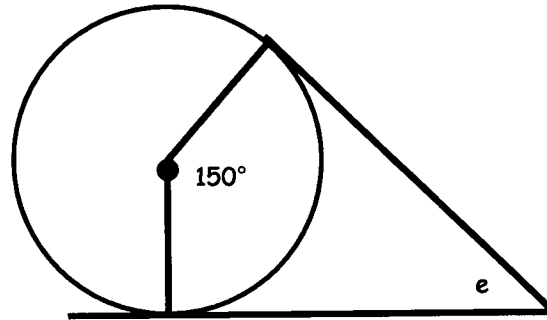
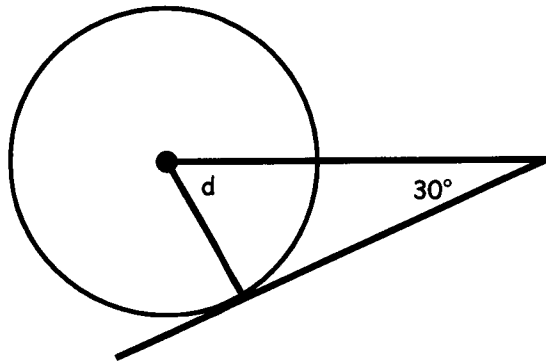
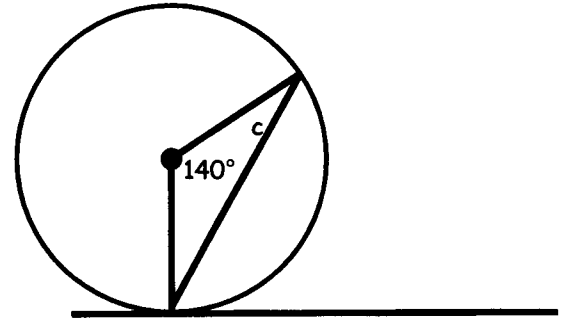
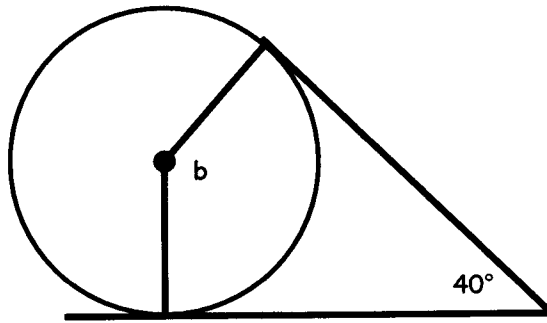
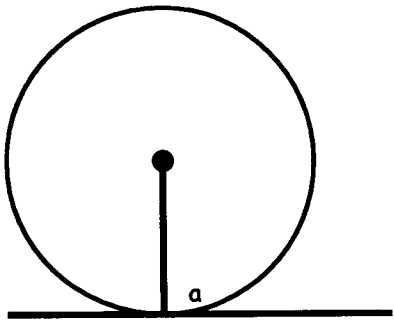

(4)

Circle Theorems

1

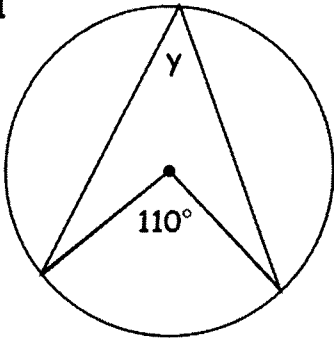

2

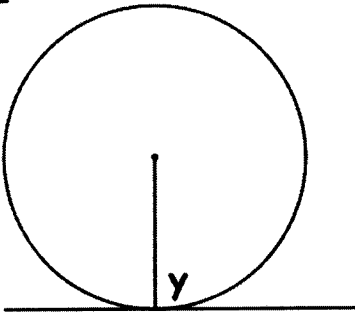

3

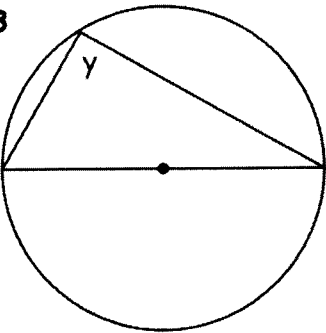

4

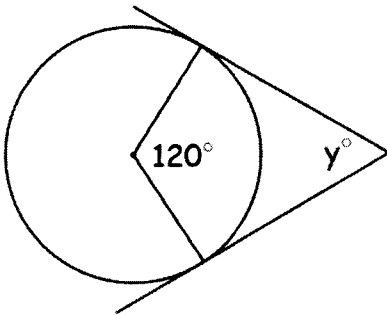

5

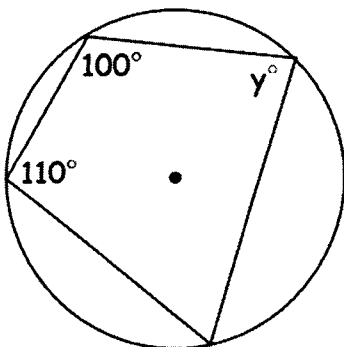

6

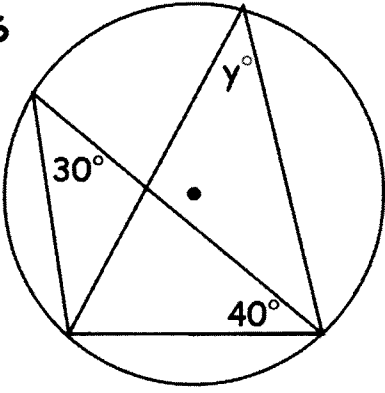

7

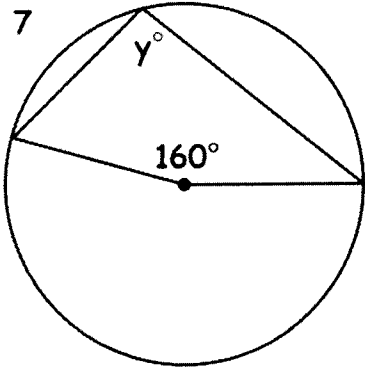

8

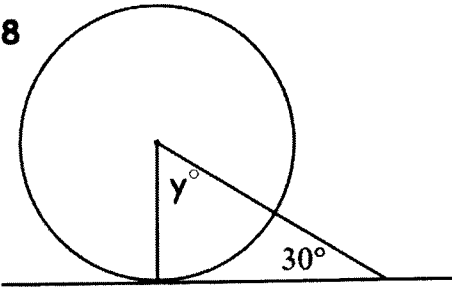

9

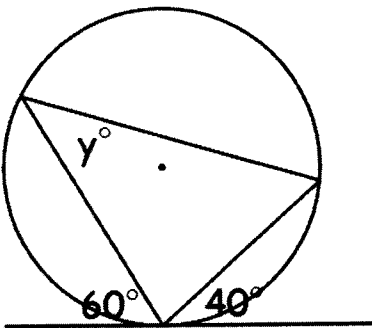

10

